

Original Research Article

Comparative Studies of Two Developed On-Farm Solar Dryers for Vegetables

ABSTRACT

This research work was carried out to provide local farmers with on-farm solar dryers to minimize post-harvest losses of vegetables. Two dryers (Mixed mode and Indirect mode on-farm solar dryers) were constructed using locally available materials. The dryers basically consist of a blower, a collector area and a drying chamber. Aluminum sheet is placed inside the collector which serves as the absorbing material. An electrical axial fan was placed before the air duct to supply air responsible for forcing heated air to blow over the vegetables to be dried. Incorporated in the drying chamber are trays which provide a platform where the products to be dried were spread evenly. Transparent polythene material of 0.2mm thickness with wooden frame was used as cover for the dryers. The dryers were evaluated to determine drying time and performance efficiencies, using Baobab leaves, Tomato and Okra slices as test crops. Collected data were analyzed using Statistical Analysis Software (SAS). The effects of variation of the independent factors were verified using Analysis of variance (ANOVA) at 1% and 5% levels of significant. Mean separation was carried out on significant factors using Duncan Multiple Range Test (DMRT). The results obtained showed the performance of the developed dryers, which indicates that drying time of mixed mode on-farm solar dryer stood at 56hrs and 46hrs while that of the indirect mode dryer was 76.67hrs and 57hrs, and that of open sun drying was 154hrs and 127hrs for tomato and okra slices respectively. Results obtained showed that average system drying, energy collection and pick up efficiencies for the three test crops were 16.35 %, 21.1% and 8.05% for mixed mode dryer respectively and 28.63%, 45.3% and 0.3% for indirect mode dryer, respectively. From the results obtained the mixed mode dryer dried all the products faster while indirect mode has superior energy efficiencies.

Key Word: Vegetables, on-farm, Mixed mode, Indirect mode, dryers.

1.0 INTRODUCTION

Fresh vegetables are important foods both from economic and nutritional point of view. Vegetable of all types are valuable part of our diet. They play an important role in maintaining general good health owing to the presence of mineral elements and vitamins [1]. Many vegetables are highly seasonal in nature, they are available in abundance at a particular season and sometimes result in market glut, while at off-season they become very scarce and expensive.

Statistics indicates that the production level of tomato as at 2018 in Nigeria is approximately 3.91 million tones with the bulk of production credited to the Northern part of the country [6]. Okra production as at 2018 in Nigeria was approximately 2,033.129 tones, which makes Nigeria the second largest producer of Okra after India [6]. In the case of Baobab, it is a naturally occurring non timber forest plant found within the savanna area of northern part of Nigeria [2]. Baobab tree produces fresh leaves in abundance during the rainy season and sheds the leaves during the dry season.

Due to the perishable nature of fruits and vegetables, huge quantity of vegetables is lost within a short period. The post-harvest loss in fruits and vegetables in developing countries like Nigeria

has been estimated to be about 45% [6]. This heavy loss has been attributed to inadequate post-harvest handling, lack of infrastructure, processing, marketing and storage facilities. Vegetables either fresh or processed are preserved by various methods, which include drying, canning, air-cooling and refrigerated storage. The choice of preservation method employed is normally dependent on availability of resources and facilities.

Drying is a major way of removing moisture from agricultural products to minimise post-harvest losses which can be achieved through open sun drying, hot air drying, freeze drying, and micro wave drying [9]. Traditionally on the farm, vegetables are dried by spreading the fresh products on mats, tarred roads or cemented floors. However, this method results in poor quality of dried vegetable products due to uncontrollable weather conditions, dust particles, and other contaminating substances. [3] reported that products dried using solar dryers have good texture, color and nutritive content when compared with products dried using conventional open sun drying.

Despite the development of several solar dryers over the years, open sun drying is still prevalent due to non-availability of on-farm solar dryers, which are required to handle the large volume of fresh fruits and vegetable products at peak season. Products from open sun drying are seen in the market having dark and not easily acceptable colors especially in dried tomatoes, which might be as a result of long exposure of the products to ultraviolet radiations from the sun as mentioned by [15]. Large industrial dryers with less time of drying and high batch capacity are better options in reducing post-harvest losses of fruits and vegetables. However, these dryers are complex to operate and also require huge capital to install and maintain. For these reasons, industrial dryers such as the belt conveyor dryer developed by [10], and a micro wave dryer developed by [7], are out of reach of local farmers in Nigeria.

As reported by [14], [12], [11] and several other researchers and from the preliminary study conducted, acceptability of any dried fruit or vegetable is dependent on physical appearance, taste and nutritional content of the product. These desirable qualities are mainly influenced by the drying method, drying temperature, relative humidity and solar radiation. In order to ensure the continuous availability of vegetables and to enable the farmers to produce high quality marketable products, we came up with the design of a mixed mode and an indirect mode on-farm forced convection solar dryers with adequate capacity, efficiency, easy to operate and affordable by local farmers/ local communities.

2.0 MATERIALS AND METHODS

2.1 Design of On-farm solar dryers for vegetables

Designing is a very important aspect of engineering works, as such to design the on-farm solar dryers some considerations were necessary which include: collector with high absorptive capacity that can be built on the floor of the farm, dryer with efficient means of air circulation and drying chamber that can accommodate 120kg of sliced tomato per batch.

2.1.1 Basic Theory

i. The amount of water to be removed from the crops is obtained from

$$M_w = \frac{M_p(M_i - M_f)}{100 - M_f} \quad (1)$$

Where,

M_w = amount of moisture to be removed (kg), M_p = mass of product to be dried (kg)

M_i = initial moisture content of product to be dried (%) and M_f = Final/ safe moisture content wet basis (%)

ii. Energy required to evaporate available moisture is given by,

$$E = W_m C_{p_m} (T_2 - T_1) + I_v W_i \quad (2)$$

Where,

E = Collector useful energy gain (kJ), W_m = Weight of material to be dried (kg), C_{p_m} = Specific heat of material to be dried (kJ/kg), T_2 = temperature of air inside dryer ($^{\circ}\text{C}$), T_1 = ambient air temperature ($^{\circ}\text{C}$), I_v = heat of vaporization of air inside dryer (kJ/kg) and W_i = weight of moisture to be removed (kg).

iii. Useful energy collection rate is calculated using,

$$Q_u = F_R h_e I_H A_c \quad (3)$$

Where,

Q_u = Total useful energy collection rate (KJ/h), A_c = Collector area (m^2), F_R = Heat removal factor, h_e = Effective transmittance and I_H = incident solar radiation (W/m^2)

iv. Air flow rate adequate to blow the evaporated moisture is calculated using the relationship,

$$Ma = \frac{Q_u}{C_p (T_2 - T_1)} \quad (4)$$

Where,

Ma = Mass flow rate of air (kg/s), Q_u = Useful energy gain flow rate (KJ/s) and C_p = Specific heat of air at T_2 ($\text{KJ}/\text{Kg}^{\circ}\text{C}$)

v. System drying efficiency (η_d) is given as

$$\eta_d = \frac{M_w h_{fg}}{I A_c t} \quad (5)$$

Where,

η_d = System drying efficiency, M_w = mass of evaporated moisture (kg) h_{fg} = latent heat of vaporization (kJ/kg), A_c = surface area of the collector (m^2), I = insolation on collector surface (W/m^2) and t = time taken to evaporate the moisture (s).

vi. Collector efficiency (η_c) given as the ratio of useful heat gain over any time period to the incident solar radiation over same period. It is expressed as:

$$\eta_c = \frac{m C_p (T_o - T_i)}{A_c I} \quad (6)$$

Where,

η_c = collector efficiency, m = total mass of air (kg), C_p = specific heat of fluid ($\text{J}/\text{kg}^{\circ}\text{C}$)

T_o = air temperature at collector outlet ($^{\circ}\text{C}$) and T_i = air temperature at collector inlet ($^{\circ}\text{C}$)

- vii. Pick-up efficiency for indirect mode solar dryer (η_p) given as a ratio of the moisture picked up by the air in the drying chamber to the theoretical capacity of the air to absorb moisture. For indirect cabinet dryers, it can be expressed as;

$$\eta_p = \frac{h_o - h_i}{h_{as} - h_i} \quad (7)$$

Where,

η_p = pick-up efficiency for indirect mode solar dryer, h_o = absolute humidity of air leaving drying chamber, h_i = absolute humidity of air entering drying chamber and h_{as} = adiabatic saturation humidity of air entering the dryer.

- viii. Pick up efficiency for mixed mode solar dryer is expressed by the following

$$\eta_p = \frac{M_o - M_t}{V \cdot \rho \cdot t \cdot (h_{as} - h_i)} \quad (8)$$

Where;

η_p = Pick up efficiency for mixed mode solar dryer, M_o = mass of commodity at time $t=0$, (kg) M_t = mass of commodity at time t , (kg) and V = air flow rate (m^3s^{-1}), P = air density (kgm^{-3}) and t = drying time (sec), h_{as} = adiabatic saturation humidity of air entering the dryer and h_i = absolute humidity of the air entering the dryer

2.2 Description of the developed dryers

Figures 1 and 2 shows the schematic diagram of the developed mixed mode and indirect mode on-farm solar dryers for vegetables.

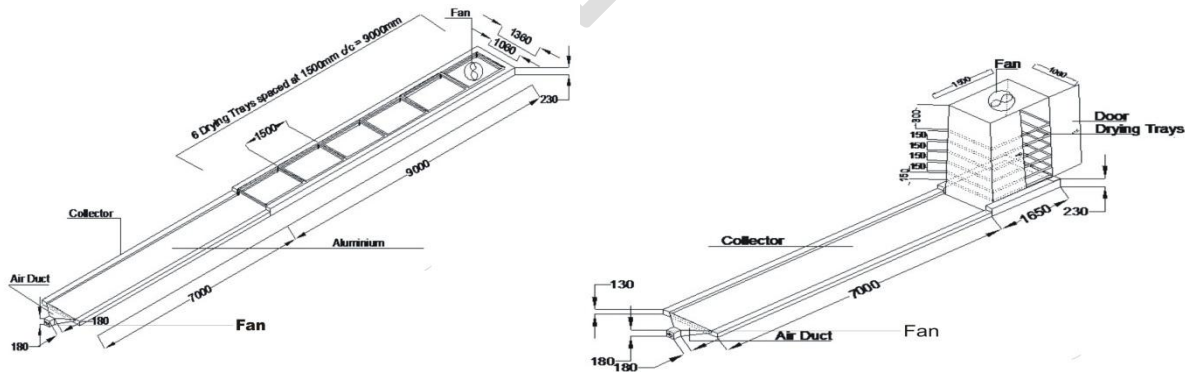

Figure 1: Mixed mode on-farm solar dryer. Figure 2: Indirect mode on-farm solar dryer.

2.3 Construction Details

The constructed on-farm solar dryers are shown in figures 1 and 2. The materials used in the construction includes: 300x 200 x 150mm cement blocks, cement, 2x2 planks (for structural and tray frames), transparent polythene, wire mesh, black paint, nails, zinc sheets and 0.7mm aluminum sheets. Cement blocks were used to make foundation. The collector foundations measures 600.00cm x 106.00cm x 13.00cm. The drying chamber foundation for the mixed mode dryer, measures 900.00cm x 106.00cm x 23.00cm. The floor and side of the foundation

was plastered with a mixture of cement, sand and water. The transparent polythene attached to a wooden frame was used as a glazing surface to cover the collector area and the drying chamber of the mixed mode dryer. Aluminium sheets of 0.7mm thickness and painted black was used as the absorber material in the collector area. Planks were used to form a 150.00cm x 120.00cm x 100.00cm frame for the drying chamber of the indirect mode dryer. Zinc sheets painted black were then used to cover the frame of the indirect mode dryer. Door of the indirect mode dryer was constructed with wood measuring, 150.00cm x 120.00cm. Air ducts for conveying air from the blower to the collector surface was fabricated from gauge 18 mild steel sheet. The air ducts measures, 18.00 cm diameter inlet and 13.00cm x 8.00cm outlet to the collector. New climate axial fans were used as blowers for the two dryers. Provisions were made in the upper part of the indirect mode dryer and towards to end of the drying chamber of the mixed mode dryer for proper ventilation. The six trays each for the indirect mode and mixed mode dryer were made with wooden frame, 150cm x 106cm and wire mesh. The six trays of the indirect mode dryer were separated with a gap of 15.00cm. Figure 3 and figure 4 shows the pictorial view of the constructed on-farm solar dryers.



Figure 3. Indirect mode on-farm solar dryer Figure 4. Mixed mode on-farm solar dryer

2.4 Experimental Procedures

The performance of the developed dryers was evaluated experimentally using the developed dryers and open sun drying using tomato, okra and baobab leaves as test crops. The following parameters were measured: (a) radiation incident on the collector, (b) air temperatures at various locations in the collector and dryer and (c) relative humidity of air. To measure the amount of solar radiation, an IR digital pyrometer model HT-6889 with spectral response of 8~ 14 μ m was used whereas, both temperature and humidity of air at various locations of the dryers were measured using a smart sensor Model WS-10-X4 with accuracy of $\pm 1^{\circ}\text{F}$ were placed at the various points along the length of the dryers. All data were registered at an interval of 3hrs. Drying test was started at 8am and stopped at 6pm daily.

3.0 RESULTS AND DISCUSSION

Figure 3 is the plot of the temperatures in hours ($^{\circ}\text{C}$) versus local time (hrs) for performance evaluation of dryers under no load conditions. This gives a measure of the ability of the dryers to heat up ambient air. The ambient temperature as at March, 19 2017 when the experiment was

carried out ranged from 24 to 36⁰c. It was observed that the air temperature of the mixed mode dryer is higher ranging from 25 to 55.9⁰c than that of the indirect mode dryer which ranged from 24 to 45.1⁰c, this is due to the fact that the drying chamber of the mixed mode dryer receives heat from both the collector and direct sun light, were as the drying chamber of the indirect mode dryer receives heat from the collector and slight heat through conduction from the zinc

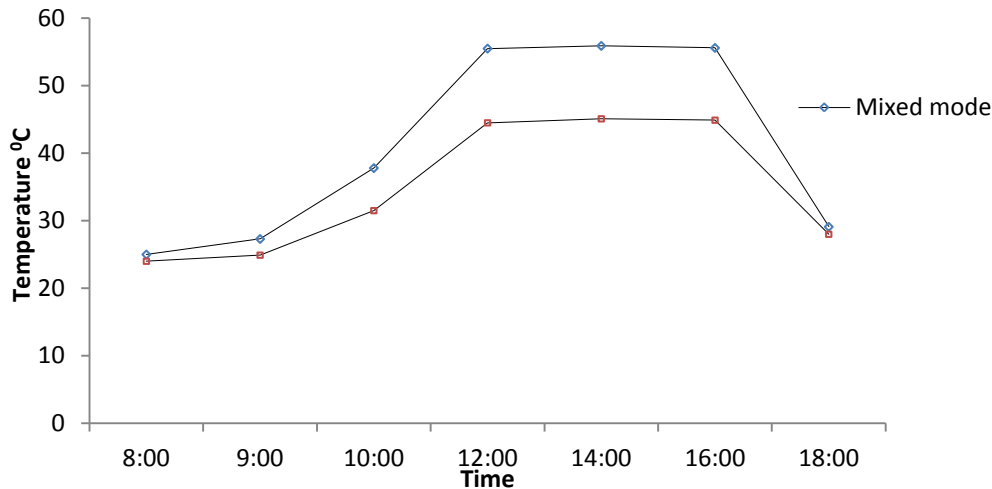

Figure 5. Variation of drying chamber temperature with local time for unloaded dryers

Figure 6 is a plot of the drying characteristics of tomato under the mixed mode on-farm solar dryer and under open sun. Fresh tomato which was at 94% initial moisture content was observed to dry at constant rate until the moisture was reduced to about 40-60% moisture content wet basis. It can be observed that tomato slices in tray 1 of the mixed mode dryer (MSDP1) dried in 52hrs while tomato slices in tray 3 and tray 5 dried in 58hrs. However, tomato slices under open sun (OSD) took 147hrs to dry. Tomato slices in tray 1 dried faster compared to tomato slices in tray 3 and 5 because, products in tray 1 received more heat from the collector than those in tray 3 and 5. Drying tomatoes under the mixed mode dryer saves about 3days, [4] in their work stated that mass transfer in mixed mode is faster compared to indirect mode due to increase in heating of the samples in the mixed mode creating a difference in vapor pressure greater than in the indirect mode dryer. Figure 7 is a plot of the drying characteristics of tomato under the indirect mode dryer. Fresh tomato slices in tray 1 (ISDP1) dried in 72hrs which is faster when compared to those in tray 3 and tray 5, which both dried in approximately 79hrs.

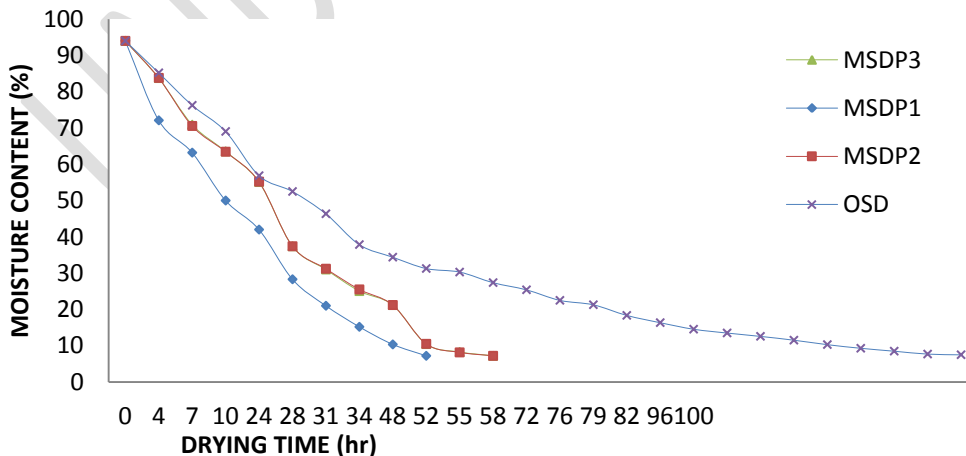

Figure 6 Drying characteristics of Tomato Slices in Mix-mode solar dryer and Open Sun Drying

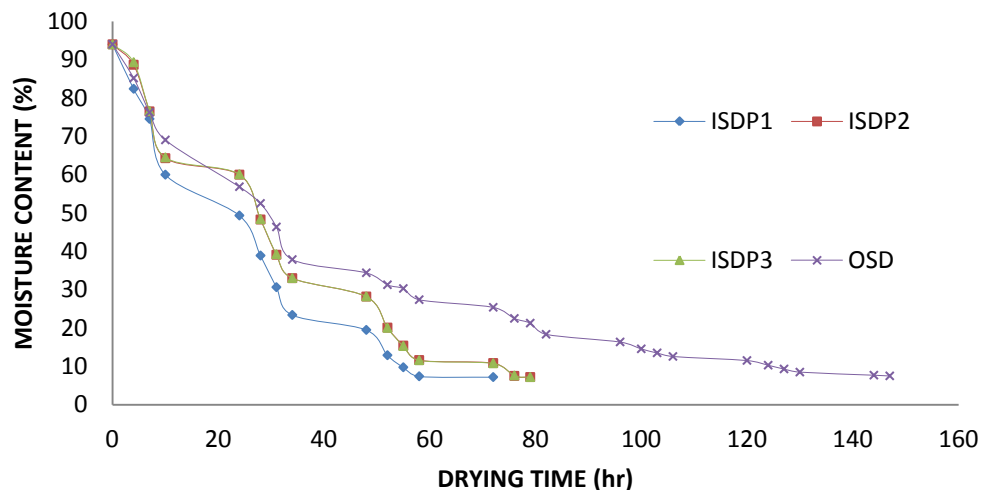

Figure 7. Drying characteristics of Tomato Slices in Indirect mode solar dryer for vegetables and Open Sun Drying

Figure 8 is a plot of the drying characteristics of okra slices in the mixed mode dryer. Fresh okra slices at 86% moisture content experienced an initial rapid moisture loss, afterwards the remaining drying period took place in falling rate state. Okra slices in tray 1 dried faster in 34hrs than those in tray 3 and tray 5 which dried in 52hrs each. However okra slices under open sun dried in 127hrs.

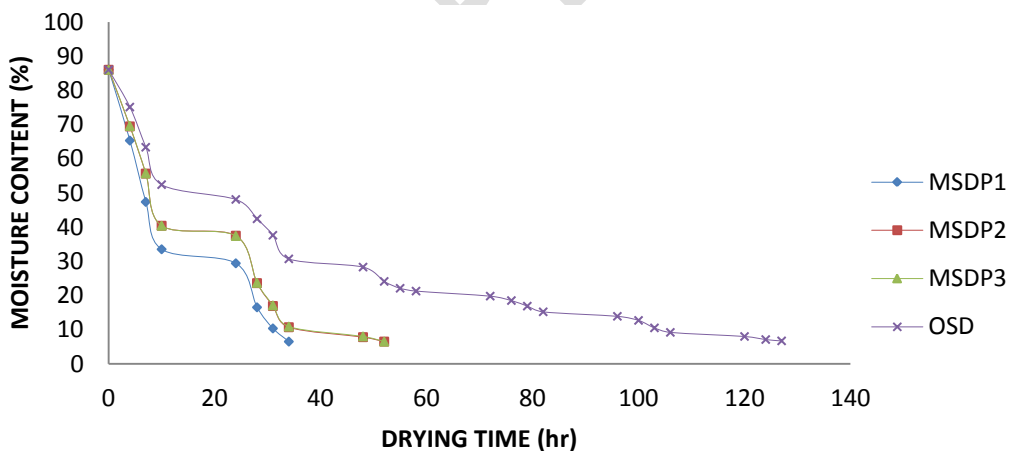

Figure 8 Drying characteristics of Okra slices in mixed mode solar dryer for and Open Sun Drying

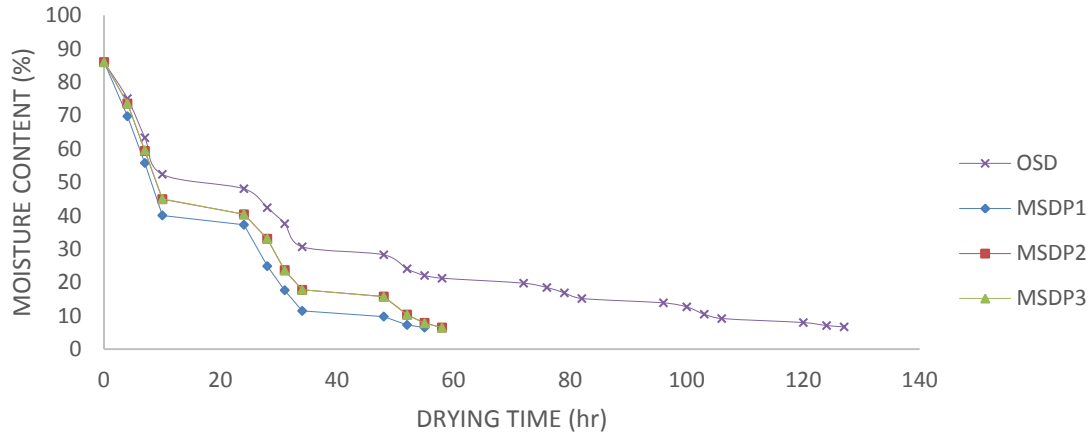

Figure 9 Drying characteristics of Okra slices in Indirect mode solar dryer for vegetables and Open Sun Drying

Figures 10 and figure 11 shows the drying characteristics of baobab leaves under mixed mode and indirect mode respectively. Generally baobab leaves dried in within a short period when compared to tomato and okra. However, the drying trend is similar to that of tomato and okra in that the leaves in tray 1 dried within a shorter period compared to those in tray 3 and 5. As at the time of preparing this research work little information exists about the drying of baobab leaves.

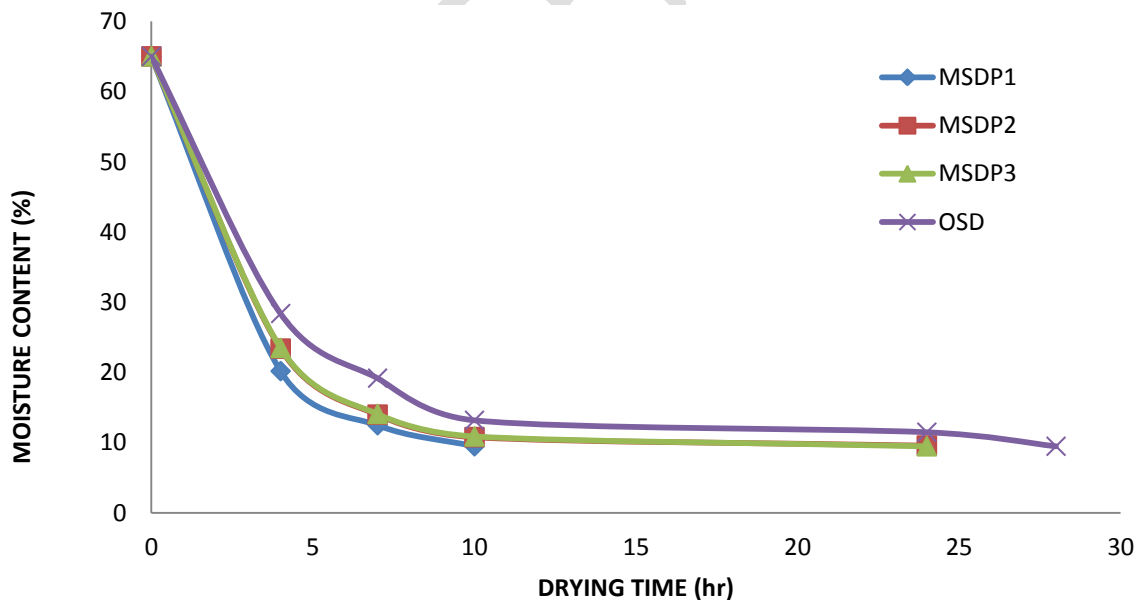

Figure 10 Drying characteristics of baobab leaves in mix-mode solar dryer and open sun drying

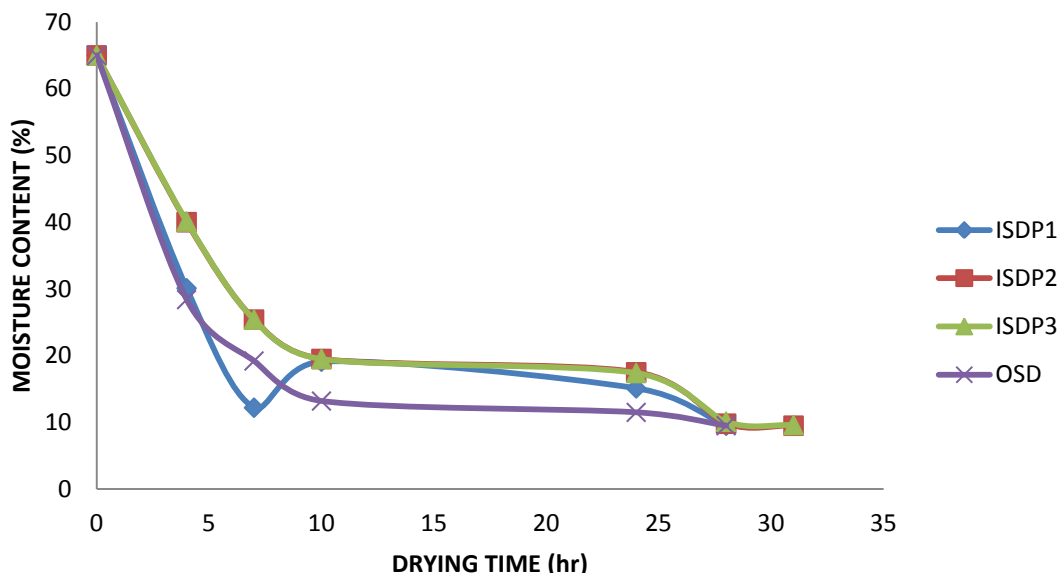

Figure 11. Drying characteristics of baobab leaves in indirect mode solar dryer and open sun drying

Table 1 shows the result of the drying parameters and the performance evaluation carried out on the developed on-farm solar dryers. Heat flow into the dryers was measured 72.07W/m^2 . The drying rate for tomato slices stood at 30.50g/day for the indirect mode dryer, 41.76g/day for the mixed mode dryer and 15.18g/day under open sun. This indicates the mixed mode dryer dries vegetables faster than the indirect mode dryer.

Table 1. Evaluated Parameters of the Dryers

Parameter	Values Obtained
Heat flow into the dryers (Q/A)	72.07 W/m^2
Drying Rate	30.50g/day : Indirect mode dryer 41.76g/day : Mixed mode dryer 15.18g/day : Open sun
Moisture Content	94% Tomato 86% Okra 64% Baobab
Collector Area	3.36m^2
Drying Efficiency (Average)	26.3% (per day): Indirect dryer 16.3% (Per day): Mixed mode dryer
Collector Efficiency (Average)	44.8% : Indirect dryer 21.2 % : Mixed mode dryer
Pickup Efficiency (Average)	0.4% : Indirect mode dryer 8.1% : Mixed mode dryer

The collector area was measured at 6.36m². Average system drying efficiency for the Mixed mode dryer was 16.3% and that of the indirect mode dryer was 26.3%. These findings are in line with results obtained by [4]. In their research, they reported the range of drying efficiency lies between 6% to 20%, meanwhile a lower drying efficiency in mixed mode (5.47%) and in indirect mode (4.48%) was obtained by [4] when they compared the thermal performance of a passive and a mixed-type solar dryer for tomatoes. From the above findings, the indirect mode dryer has a more satisfactory drying efficiency (26.3%), this shows a good level of air circulation within the drying chambers of the indirect mode dryer [13]. The indirect mode dryer also gave a higher collector efficiency of 44.8% as compared the mixed mode dryer which has a collector efficiency of 21.2%. The efficiency of the solar collector of the indirect mode dryer in this work is similar to that obtained by [5], (52%). Variation of energy collection efficiency varies greatly due to a number of factors mostly uncontrollable as they are weather dependent (mainly irradiance and psychometric)

Pick-up efficiency recorded for both dryers were very low (8.1% and 0.4%) compared to the findings of Isaac and Sam (35%), [8]. This shows that the ability of the heated air in dryers to absorb moisture is underutilized. This means that air velocity is high as such the passing air has limited time lag to fully absorb moisture from the drying material.

CONCLUSION

A mixed mode and an indirect mode on-farm solar dryer for vegetables were designed and constructed successfully, using locally available materials. The mixed mode dryer achieved a highest drying chamber temperature of 55.9^oc while the indirect mode dryer recorded a highest temperature of 45.1^oc. Drying of tomatoes was achieved in an average time 56hrs and 76.67hrs for mixed mode and indirect mode dryers respectively, while okra slices dried in 46hrs and 57hrs in mixed mode and indirect mode dryers respectively. The mixed mode dryer dried all the products faster while indirect mode has superior energy efficiencies. System drying, collector and pick-up efficiencies stood at 16.6%, 21.2% and 8.1% for mixed mode dryer respectively and 26.3%, 44.8% and 0.4% for indirect mode dryer respectively. These developed dryers can be used by local farmers to dry excess vegetable products to reduce post-harvest losses.

REFERENCES

1. Adegunwa, M.O., Alamu, E.O., Bakare H. A. and Oyeniyi, C.O. (2011). Proximate and Bioactive Contents of Some Selected Vegetables in Nigeria. *American Journal of Food and Nutrition.1(4)*: Department of Agricultural Engineering, A.B.U. Zaria, Nigeriain. 2011: 171-177
2. Amusa, T.O., Aderinoye-Abdulwahab, S.A., Akanbi, S.O. and Idowu, O. P. Uses and Prevalence of African Baobab (*Adensonia digitata LI759*) in Okkoo Community, Kwara State, North-Central Nigeria. *Nigeria. Journal of Agriculture, Food and Environment. 2017; 13(1):43-49.*
3. Aravindh, M. A. Solar drying- a sustainable way of food processing. *Green energy and technology. 2015;201:27-46.*
4. César LV E, César M A L, GarcíaV O, Pilatowsky F I and Brito O R. *Thermal. Renewable Energy. 2020;147:845-855. DOI: doi.org/10.1016/j.renene.2019.09.018.*

5. D.V.N. Lakshmi, P. Muthukumar, A. Layek, P.K. Nayak. Drying kinetics and quality analysis of black turmeric (*Curcuma caesia*) drying in a mixed mode forced convection solar dryer integrated with thermal energy storage. *Renew. Energy*. 2018; 120: 23-34.
6. FAO (2019). FAO STAT:Accessed 21st Feb., 2020 Available: <http://www.fao.org/faostat/en/#data/QC>.
7. Gbenga, A. O., Atungulu, G., Smith, L. D. One pass drying of rough rice with an industrial 915MHz microwave dryer. Quality and energy use consideration. 2017;55:33-43.
8. Isaac N S and Sam C. Design and Testing of a Natural Convection Solar Tunnel Dryer for Mango. *J. of Solar Energy*. 2017:10pages. DOI: <http://doi.org/10.1155/2017/4525141>.
9. Isiaka, M. . Development of Low Energy Force Convection Solar Dryer for Sliced Tomato. Unpublished Ph.D. Dissertation. Department of Agricultural Engineering, A.B.U. Zaria, Nigeria. 2009:30-80
10. Mehrdad, S. and Majid, A. Design and Optimization of Solar Assisted Conveyer-belt Dryer for Biomass. *Energy Equipment and Systems*. 2017;5(2):1-10
11. Nighitha M T and Santhi M M. The Effect of Drying on the Shelf life of Amaranthus Leaves. *Int. Res. J. of Eng & Tech*. 2019;6(02):219-222. P-ISSN:2395-0072
12. Ravi D S, Anurag P and Avanish K. Tray Drying Characteristics of Onion Slices and Physicochemical Analysis of Dried Onion Powder. *Int. J. Curr. Microbiol. App. Sci*. 2019; 8(04): 2468-2483. Doi:<https://doi.org/10.20546/ijcmas.2019.804.288>
13. Seyfi Ş, Mustafa A, Ekin C D, Erhan A and Azim D T. Performance analysis of solar and solar-infrared dryer of mint and apple slices using energy-exergy methodology. *Solar Energy*. 2019;180:537-549. DOI:doi.org/10.1016/j.solener.2019.01.049
14. Ullah I and Khan S. Effects of Spices and Salt on the Overall Acceptability and Preservation of Tomato Cubes. *Food and Nutrition J*. 2019;4:194. DOI:10.29011/2575-7091.100094
15. Vipin, S., Anil, K. and Prashant, B. Developments in Indirect Solar Dryer: A Review. *International Journal of Wind and Renewable Energy*.2014; 3(4): 67-74.

Nomenclature

MSD P1	1 st tray from bottom in drying chamber of the mixed mode dryer
MSD P2	3 rd tray from bottom in the drying chamber of the mixed mode dryer
MSD P3	5 th tray from bottom in the drying chamber of the mixed mode dryer
ISD P1	1 st tray from bottom in drying chamber of the indirect mode dryer
ISD P2	3 rd tray from bottom in the drying chamber of the indirect mode dryer
ISD P3	5 th tray from bottom in the drying chamber of the indirect mode dryer
OSD	Open sun drying