

Mechanization of Ginger Slicing for Peasant Farmers

ABSTRACT

Dual (cushion and spring) compartment ginger slicing machine was developed to address the difficulties associated with manual slicing of ginger. However, there is no established operational performance on record for this particular machine; thus, the need for this study. To achieve this, the machine performance was evaluated at the Department of Agricultural and Bio-Environmental Engineering, Waziri Umaru Federal Polytechnic, Birnin Kebbi in April, 2019 in terms of Slicing Efficiency and Percent Broken and Bruises at a ginger moisture content of 80.2 and 78.5%, using completely randomized Design (CRD) with 5 x 2 x 2 factorial experiment. The experiment was conducted with one horse power petrol engine. The data collected were analyzed using Analysis of Variance (ANOVA) at significance level of the experimental factors and their interactions and those found significant were further analyzed using Duncan Multiple Range Test (DMRT) for mean separations at (P0.05), respectively. The results showed that, Slicing Efficiencies for cushion and spring compartments were: 61.2 and 45.1%, respectively. The lowest mean Percent Broken and Bruises was with cushion compartment as 38.8% and 54.9% spring compartment, respectively

Keywords: Slicing Efficiency, Percent Broken and Bruises, Evaluation, DMRT, Ginger

1. INTRODUCTION

Ginger can be grown on sandy loam and clay loam soil with good drainages and a lot of organic matter [3]. The chemical components of ginger rhizome can vary considerably depending on the location of the cultivation and whether the product is fresh, dried, or processed [10]. The rhizome contains 3 – 6% fatty oil, 60 – 70% carbohydrates, 9% protein, about 8% ash, 3 – 8% fiber, 9 – 12% water, and 2 – 3% volatile oil [8]. Ginger can be processed into powder, pharmaceutical, volatile oil, and oleoresin. Its use in culinary applications dates as far back as the 13th century [11]. Among all spices, ginger exhibits one of the greatest diversity of uses, such as in dietary supplements, beverage (such as ginger ales), and food products such as in curry powder, confectionaries, soups, jams, and baked goods [17]; [3]; [3]. Nigeria is the largest producer in Africa with a volume of 522,964 metric tons but second in the world [7]. The ginger is an important source of foreign exchange for Nigeria. The plant is grown in different parts of Nigeria such as Kaduna, Nasarawa, Sokoto, Zamfara, Akwa Ibom, Oyo, Abia and Lagos States, although Kaduna is the largest producer of fresh ginger in Nigeria [14]. Producing areas in Kaduna State are Zaria, Jaba, Jamaa and Kachia [5]; [3]. As reported by [6], ginger has a moisture content of 80 - 85% wet basis when freshly harvested and 10 - 12% moisture content dry basis for storage. Ginger enters the international markets as fresh, preserved or dried forms. However, the most important commercial form is the dried ginger (split or whole) [3]. Dry whole and sliced ginger are the most needed in international market though the whole dry

ginger takes longer time for the product to get dried-up and ready for sales [3]. Report by [4], stated that demand for dry ginger locally and internationally is becoming greater. Slicing longitudinally is to enable maximum surface exposure for quick and uniform drying thereby retaining the aroma, flavour and pungency which are the qualities requirements in ginger trade [16]. Traditional method of slicing is the most practiced. It involves use of kitchen knife which has different edge directions, the moisture content and the cross sectional area has significant influence over the cutting energy. This necessitate the development of the dual compartment ginger slicing machine; but, there is no established operational performance on record for this particular machine; thus, the need for this study.

2.0 MATERIAL AND METHODS

The instruments used for measuring mass and shaft speed were: Mettler Model (PN20001) top loading balance with capacity of 2 kg and accuracy of 0.1 gram and Lutron Digital Photo Tachometer that can measure a range of 0.5 to 100,000 rpm and accuracy of 0.05% + 1 digit.

2.1 Description of the Dual Compartment Ginger Slicing Machine

The dual compartment ginger slicing machine consists of the following components: frame, hoppers, slicing units, and power transmission unit as in Figure 1.

2.1.1 Frame: the machine had trapezoid dimensions of the parallel sides as 600 mm and 960 mm, and height of 300 mm. The frame was fabricated with 30 mm × 30 mm × 3mm angle iron. Mounted on the frame are bearings, shaft, slicing units, hoppers and a prime mover.

2.1.2 Hopper: the hoppers are rectangular in cross section and made from 3 mm mild steel sheets. They had 190 mm × 150 mm × 65 mm dimensions as length, breath and width with an inclination of 42°.

2.1.3 Slicing units: the chamber is composed of two types of slicing chambers, spring and cushion compartments to accommodate the irregular thickness of ginger rhizomes. The slicing chambers had cross sections of 300mm × 300mm and widths of 50 mm. The widths of chambers were to accommodate all thickness of ginger. It compresses/deflects when a bigger size is fed into the chamber.

The cutting blades (saw blade) are sharpened at one side and were stationary positioned at a tension through adjustable device to prevent distortion during operation. It has overall dimensions of 400 mm × 30 mm × 1.6 mm.

Impeller of 145 mm × 20 mm × 5 mm cross section were fabricated and keyed to a rotating shaft. The impellers were curved and spaced equally at 7 mm across the cutting blades lateral cross sections and along the shaft's longitudinal axis to avoid obstruction.

2.1.4 Power transmission unit: V- Belt and pulley assembly were used to transmit the power from the prime mover to the slicing chambers at different levels of impeller speeds. The prime mover is mounted on a frame slit to facilitate adjustment of the belt tension.

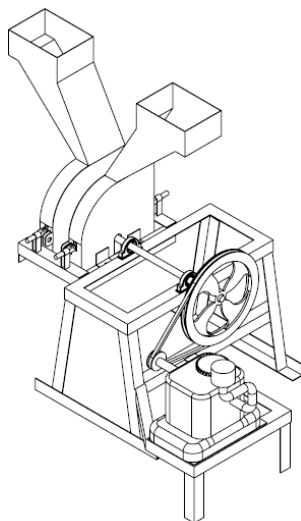

Fig. 1. Isometric view of the dual compartment ginger slicing machine

2.2 Experimental procedure

Fresh ginger was purchased from local market in Kafanchan Local Government Area of Kaduna State. Equal weights of 500 gram each of the two varieties (Tafin Giwa and Yatsun Biri) were used for the experiment. The ginger rhizome was fed through the hopper and slides down to the respective slicing units (spring and cushion compartments). The sliced were collected in a container through the outlet just below the slicing chambers. The collected ginger was separated and weighed to determine the slicing efficiency and percent broken and bruises. The speed of impeller was varied into five levels (250, 300, 350, 400 and 450 rpm). The experiment procedures were repeated three times. The pictorial view of the dual compartment ginger slicing machine in operation is shown in Figure 2.



Fig. 2. Operating the dual compartment ginger slicing machine

2.3 Statistical Analysis

The speed of the impeller, slicing compartment and ginger variety were taken as independent variables. The variables were arranged in 5x2x2 factorial experiment fitted into Completely Randomized Design (CRD). This gave a total of 20 treatments, while replication gave 60 runs. Data from the performance evaluation was subjected to statistical analysis using Analysis of Variance (ANOVA) to test the significance of experimental factors and their interactions. Mean

separation with observed significant differences was compared using Duncan's Multiple Range Tests (DMRT) using SAS 9.13 portable package. The ANOVA was computed at probability level of ($p < 0.05$).

2.4 Performance Evaluation Indicators

The machine was evaluated based on slicing efficiency and percent broken an bruise:

2.4.1 Determination of slicing efficiency

The slicing efficiency is the ratio of effective capacity to theoretical capacity expressed in percentage. The slicing efficiency was determined as given by [9]; [16]; [13]; [15]; [2] and [1] in Equation (1):

$$SE(\%) = \frac{B}{K} \times 100 \quad (1)$$

Where:

SE= slicing efficiency, %

B= Total quantity of ginger completely sliced, g

K= total quantity of ginger collected at outlet, g

2.4.2 Determination of percent broken and bruise

The mean broken and bruised is the ratio of injure rhizomes to total mass of the rhizomes collected as given by [9] and [16] in Equation (2):

$$PB(\%) = \frac{K-B}{K} \times 100 \quad (2)$$

Where;

K= quantity of ginger collected at outlet, (g)

B= quantity of ginger completely sliced, (g)

3. RESULTS AND DISCUSSION

3.1 Slicing Efficiency

The Analysis of Variance (ANOVA) for effect of type of compartment, ginger variety and speed of impeller on slicing efficiency is shown in Table 1. The ANOVA result indicated that all the main factors and their first order interactions except ginger variety and its first order interactions were highly significant at ($P \leq 0.01$). The second order interactions between type of compartment, ginger variety and speed of impeller were highly significant at the same level of significance.

Table 1. Analysis of Variance (ANOVA) Results for Slicing Efficiency

Source of variations	DF	SS	Mean Square	F Value	Pr > F
C	1	4869.515973	4869.515973	230.94	<.0001**
V	1	11.222918	11.222918	0.53	0.4667 ^{NS}
S	4	4263.556810	1065.889203	50.55	<.0001**
CxV	1	2.223488	2.223488	0.11	0.7458 ^{NS}
CxS	4	1094.195143	273.548786	12.97	<.0001**
VxS	4	170.104670	42.526168	2.02	0.0946 ^{NS}
CxVxS	4	519.355972	129.838993	6.16	0.0001**
Error	19	3373.66267	21.08539		
Corrected Total	38	25136.92308			

*= Significant at ($P=0.05$), **= Highly Significant at ($P \leq 0.01$) and NS= Not significant
Type of compartment, C, Number of impeller, N, Ginger variety, V, Speed of impeller, S

The results of interaction of type of compartments, ginger variety and speed of impellers are shown in Table 2. The DMRT result shows significant difference and the combination do not have definite pattern. The highest mean slicing efficiency of 61.2% was recorded with cushion compartment, black ginger variety at 250 rpm speed of impeller. The lowest mean slicing efficiency of 35.8% was observed with spring compartment with yellow ginger variety at 450 rpm

speed of impeller. Similar trend was published by [9] that slicing efficiency increased with decrease in speed of impeller. However, [12] and [2] added that combination of ginger variety and speed is not significant if the ginger sizes are similar. Hence, the difference in the efficiencies for the two varieties of ginger was not highly significant which means the machine accommodated the two varieties sizes.

Table 2. Interaction of type of compartment, ginger variety and speed of impeller on slicing efficiency

Treatment	Mean Slicing Efficiency (%)	Mean Ranking	Treatment	Mean Slicing Efficiency (%)	Mean Ranking
Cushion Compartment, C₁			Spring Compartment, C₂		
S ₁ V ₁ C ₁	61.2	a	S ₂ V ₁ C ₂	45.1	ef
S ₁ V ₂ C ₁	56.9	b	S ₁ V ₁ C ₂	43.6	ef
S ₂ V ₂ C ₁	52.8	c	S ₁ V ₂ C ₂	43.4	g
S ₃ V ₁ C ₁	50.3	cd	S ₂ V ₂ C ₂	41.6	gh
S ₃ V ₂ C ₁	50.0	cd	S ₄ V ₁ C ₂	39.3	ghi
S ₄ V ₁ C ₁	48.1	de	S ₄ V ₂ C ₂	39.3	ghi
S ₄ V ₂ C ₁	45.1	ef	S ₃ V ₂ C ₂	38.2	hi
S ₂ V ₁ C ₁	44.3	ef	S ₃ V ₁ C ₂	37.3	i
S ₅ V ₁ C ₁	41.7	fgh	S ₅ V ₁ C ₂	36.2	i
S ₅ V ₂ C ₁	39.7	ghi	S ₅ V ₂ C ₂	35.8	i

Means followed by same letter(s) on the same column and row are not different statistically at P=0.05 using DMRT.

2.4.2 Percent Broken and Bruised

The ANOVA result for effect of type of compartment, ginger variety and speed of impeller on percent broken and bruised is shown in Table 3. It shows that only ginger variety and its interactions that were not significant but other experimental factors and their interactions were highly significant. However, interaction between type of compartment, ginger variety and speed of impeller was highly significant.

Table 3: ANOVA Results for Percent Broken and Bruised

Source of Variation	DF	SS	Mean Square	F Value	Pr > F
C	1	4812.182711	4812.182711	226.63	<.0001**
V	1	8.632096	8.632096	0.41	0.5246 ^{NS}
S	4	4342.836102	1085.709025	51.13	<.0001**
C×V	1	3.622002	3.622002	0.17	0.6801 ^{NS}
C×S	4	1122.906955	280.726739	13.22	<.0001**
V×S	4	165.797194	41.449298	1.95	0.1044 ^{NS}
C×V×S	4	513.725716	128.431429	6.05	0.0001**
Error	19	3397.32163	21.23326		
Corrected Total	38	25283.88012			

*= Significant at (P≤0.05), **= Highly Significant at (P≤0.01) and NS= Not significant

The results of interaction of type of compartments, ginger variety and speed of impellers are shown in Table 4. Other experimental factors were kept constant. The Means followed by same letter(s) on the same column and row are not different statistically at P≤0.05 using DMRT. However, the combinations do not have definite pattern. The lowest mean percent broken and bruised of ginger rhizome was recorded with cushion compartment to be 38.8% with black ginger variety at 250 rpm speed of impeller and 54.9% with black ginger at 300 rpm with spring compartment. This is because; increase in impeller speed is synonymous to increase in speed of revolution. An increase in speed decreases ginger

rhizomes entry into slicing compartment by knocking the rhizomes back to the hopper. This finding is similar to the findings of [9]; [12].

Table 4. Interaction Between Type of Compartment, Ginger Variety and Speed of Impeller on Percent Broken and Bruised

Treatment	Mean Broken and Bruised (%)	Mean Ranking	Treatment	Mean Broken and Bruised (%)	Mean Ranking
<u>Cushion compartment, C₁</u>			<u>Spring compartment, C₂</u>		
S ₁ V ₁ C ₁	38.8	k	S ₂ V ₁ C ₂	54.9	fg
S ₁ V ₂ C ₁	43.1	j	S ₁ V ₁ C ₂	56.4	ef
S ₂ V ₂ C ₁	47.2	i	S ₁ V ₂ C ₂	56.6	ef
S ₃ V ₁ C ₁	49.7	hi	S ₂ V ₂ C ₂	58.4	c-f
S ₃ V ₂ C ₁	50.0	hi	S ₄ V ₁ C ₂	60.7	a-d
S ₄ V ₁ C ₁	51.9	gh	S ₄ V ₂ C ₂	60.7	a-d
S ₄ V ₂ C ₁	54.9	fg	S ₃ V ₂ C ₂	61.8	abc
S ₂ V ₂ C ₁	55.7	fg	S ₃ V ₁ C ₂	62.7	ab
S ₅ V ₁ C ₁	58.9	b-f	S ₅ V ₁ C ₂	63.8	a
S ₅ V ₂ C ₁	60.3	a-e	S ₅ V ₂ C ₂	64.2	a

Means followed by same letter(s) on the same column and row are not different statistically at $P \leq 0.05$ using DMRT.

4. CONCLUSION

The performance parameter (Slicing Efficiency and Percent Broken and Bruises) of the dual compartment ginger slicer was carried out. The best machine performance for the two ginger varieties was in terms of compartment's high slicing efficiency. The highest mean Slicing Efficiency was obtained with cushion compartment at 61.2% and 45.1% with spring compartment at 250 and 300 rpm speed of impellers with *Tafin Giwa* ginger variety, respectively. However, the lowest mean percent broken and bruises was with cushion compartment at 38.8% and 54.9% spring compartment at 250 and 300 rpm speed of impellers with *Tafin Giwa* variety, respectively.

REFERENCES

- [1] Abuabakar, I, Yusuf, DD, Mohammed, US, Abdulbasit, Z, Agunsoye, JK, Habiba, AK, Bashar, ZU. Performance Evaluation of a Portable Ginger Slicing Machine. *Journal of Engineering Research and Reports*, 2019, 5(3):1-8.
- [2] Abubakar, I, Yusuf, D. D. and Mohammed, U. S. Design and Fabrication Of A Portable Ginger (*Zingiber Officinale Roscoe*) Slicing Machine. Presented at National Engineering Conference, Faculty of Engineering, Ahmadu Bello University, Zaria. Held between 14th – 17th November. 2018, 671- 677.
- [3] Ajavi EA and Ogunlade CA. Physical Properties of Ginger (*Zingiber Officinale*), *Global Journal of Science Frontier Research: D Agricultural and Veterinary*, 2014,14(1): 1- 8.
- [4] Alakali, JS and Satimehin, AA. Moisture adsorption characteristics of Ginger (*Zingiber officinale*) Powders, *Agricultural Engineering International. The CIGR Ejournal. Manuscript* 1289, 2009,10: 1 - 19.
- [5] Aniyi, SO. Design and Evaluation of a Ginger Slicing Machine, *Journal of Agricultural Engineering and Technology (JAET)*, 2006,14(1): 12 – 17.
- [6] Emehute, JKU. Eds. *Proceedings of Three Training Workshops on Ginger Production, Processing, Utilization and Marketing held at the National Roots Ginger Research Institute, Umidiike*. 2002, 46 - 50.
- [7] Food and Agriculture Organization Statistics, (FAOSTAT). *Production Quantity of Ginger in the World Total 2011-2016*, Retrieved from www.factfish.com/statistics/. 31 October, 2018.

- [8] Ghosh, KA, Banerjee, S, Mullick, HI, and Banerjee, S. Zingiber Officinale: A Natural Gold, *International Journal of Pharma and Bio Sciences*, 2011, 2(1): 283 - 294.
- [9] Guwo, AN. *Development of a Ginger Splitting Machine*. M.Sc. thesis. Department of Agricultural Engineering, Ahmadu Bello University, Zaria. Published. 2008
- [10] Keith, S. (2010). *Ginger: An Overview of Health Benefits*, *Nutrition Today*, 45(4): 171 – 177.
- [11] Langner, E., Greifenberg S., Gruenewald, J. (1998). Ginger: History and Use. *Advance in Therapy*, 15: 25 - 44.
- [12] Leo, A and Balogun, A. Design and Performance Evaluation of a Multi-ginger Slicing Machine. *Paper presented at CIGR Section VI International Symposium on Food Processing, Monitoring Technology in Bioprocesses and Food Quality Management, Potsdam, Germany, 31 August – 02 September, 2009*, PP:622 – 640.
- [13] Murumkar, RP, Borkar, PA, Bhojar, SM, Rathod, PK and Dorkar, AR. Testing of Turmeric Slicer for Potato Slicing. *Internal Journal of Advanced Research (IJAR)*. 2016,4(10): 701 - 709.
- [14] Nmadu, JN and Marcus, PL. Efficiency of Ginger Production in Selected Local Government Areas of Kaduna State, Nigeria. *International Journal of Food and Agricultural Economics*, 2012, 2(1):39 – 52.
- [15] Silva, FHCA and Jayatissa, DN. Design and Development of a Ginger Slicer for Small Scale Spice Processors, *International Journal of Trend in Research and Development*, 2017,4(1):385 – 389.
- [16] Simonyan, KJ, Eke, BN, Adama, AB, Ehiem, JC, Onwuka, JC, Okafor-yadi, UN, ... Okapara DA. Design and Development of a Motorized Ginger Rhizomes Splitting Machine, *Journal of Applied Agricultural Research*, 2014, 6(1): 121 – 130.
- [17] World Health Organisation (2008). *Traditional Medicine*. Available online at <http://www.who.int/mediacentre/factsheets/fs134/en/>. Retrieved 21/12/2016